



## Features

- Available in a variety of pin-out configurations
- Virtually infinite electrical circuit isolation
- Extended rotational life
- RoHS compliant\*

## Applications

- Test and measurement equipment
- Medical and laboratory equipment
- Avionics controls

## Model 91, 92, 93 & 95 - Long Life Series

Initial Electrical Characteristics <sup>1</sup>	Conductive Plastic Element
Standard Resistance Range .....	1K, 5K, 10K ohms
Total Resistance Tolerance .....	10 %
Independent Linearity .....	±2 %
Effective Electrical Angle .....	240 ° ± 5 °
Output Smoothness .....	0.15 % maximum
Dielectric Withstanding Voltage (MIL-STD-202, Method 301)	
Sea Level .....	1,500 VAC minimum
70,000 Feet .....	500 VAC minimum
Insulation Resistance (500 VDC) .....	1,000 megohms minimum
Power Rating (Voltage Limited By Power Dissipation or 350 VAC, Whichever Is Less)	
+70 °C Single Section Assembly .....	1 watt
+70 °C Multiple Section Assembly .....	0.5 watt/section
+125 °C .....	0 watt
Theoretical Resolution .....	Essentially infinite
Environmental Characteristics <sup>1</sup>	
Operating Temperature Range .....	-40 °C to +125 °C
Storage Temperature Range .....	-55 °C to +125 °C
Temperature Coefficient Over Storage	
Temperature Range .....	±1,000 ppm/°C
Vibration (Single Section) .....	
Total Resistance Shift .....	±2 % maximum
Voltage Ratio Shift .....	±5 % maximum
Shock (Single Section) .....	
Total Resistance Shift .....	±2 % maximum
Voltage Ratio Shift .....	±5 % maximum
Load Life .....	
Total Resistance Shift .....	±10 % maximum
Rotational Life (No Load) .....	
Total Resistance Shift .....	±15 % TRS maximum
Moisture Resistance (MIL-STD-202, Method 103, Condition B)	
Total Resistance Shift .....	±10 % TRS maximum
Insulation Resistance (500 VDC) .....	100 megohms minimum
IP Rating .....	IP40 (potentiometer body) IP65 (shaft and bushing interface only)
Mechanical Characteristics <sup>1</sup>	
Stop Strength (A & R Bushings) .....	45.19 N-cm (4 lb.-in.)
(C & U Bushings) .....	33.89 N-cm (3 lb.-in.)
Mechanical Angle .....	300 ° ±5 °
Torque	
Starting .....	0.3 max. above average running torque
Running Torque	
Single or Dual Section (A & R Bushings) .....	0.21 to 1.06 N-cm (0.3 to 1.5 oz.-in.)
Single or Dual Section (C & U Bushings) .....	0.14 to 1.06 N-cm (0.2 to 1.5 oz.-in.)
Mounting .....	1.7-2.0 N-m (15-18 lb.-in.) maximum
Variation .....	0.35 N-cm (0.5 oz.-in.) maximum in 45 ° shaft travel
Weight (Single Section, Metal Bushing) .....	12.7 grams nominal
(Each Additional Section) .....	4 grams nominal
Terminals .....	
Soldering Condition .....	Printed circuit terminals, J-Hooks or solder lugs Recommended hand soldering using Sn95/Ag5 no clean solder, 0.025 " wire diameter. Maximum temperature 399 °C (750 °F) for 3 seconds. No wash process to be used with no clean flux.
Marking .....	Manufacturer's trademark, date code, resistance, manufacturer's part number
Ganging (Multiple Section Potentiometers) .....	2 cups maximum
Hardware .....	One lockwasher and one mounting nut is shipped with each potentiometer, except where noted in the part number.

NOTE: Performance specifications do not apply to units subjected to printed circuit board cleaning procedures.

<sup>1</sup> At room ambient: +25 °C nominal and 50 % relative humidity nominal, except as noted.

\*RoHS Directive 2002/95/EC Jan. 27, 2003 including annex and RoHS Recast 2011/65/EU June 8, 2011.

**Product Dimensions**

**Model 91 PC Pin Terminals, In-Line**

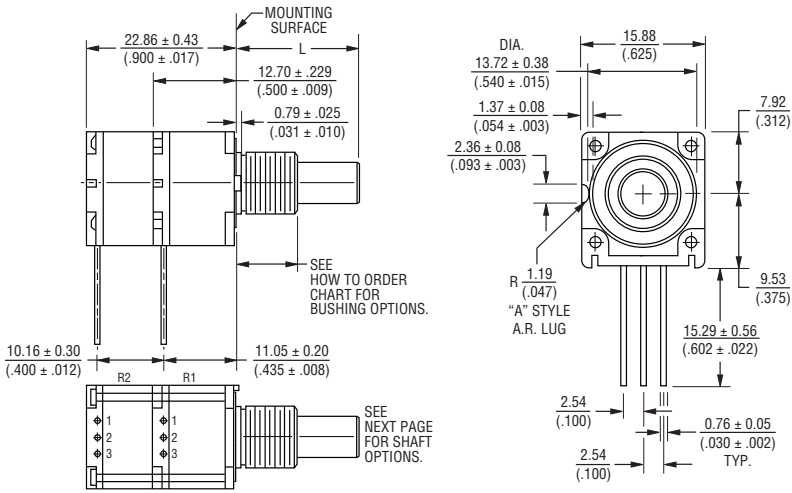

**Model 92 J-Hooked Terminals, In-Line**

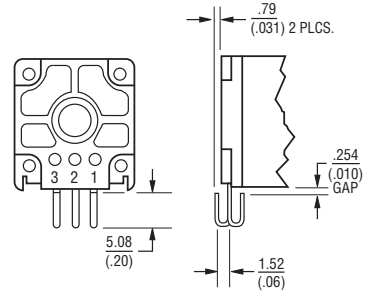

**Model 93 PC Pin Terminals, "L" Pattern**

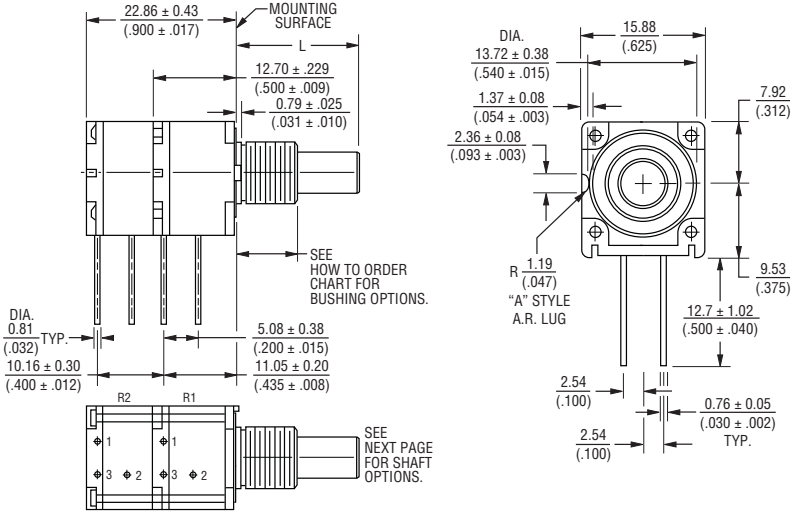

**Shaft Flat Orientation**

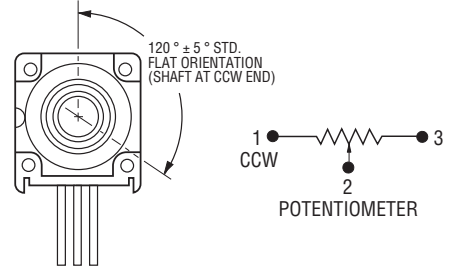

**Model 95 Solder Lug Terminals, "Triangular" Pattern**

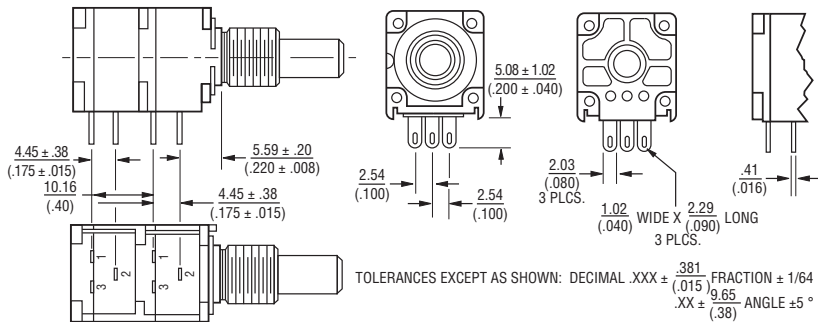

Specifications are subject to change without notice.  
The device characteristics and parameters in this data sheet can and do vary in different applications and actual device performance may vary over time.  
Users should verify actual device performance in their specific applications.

**Product Dimensions**

**SHAFT TYPE "E" (USES BUSHING C)**

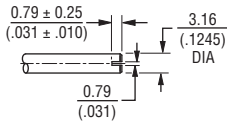

STD. LENGTHS:

12.0 (.500)	16.0 (.625)	19.0 (.750)
----------------	----------------	----------------

**SHAFT TYPE "G" (USES BUSHING A)**

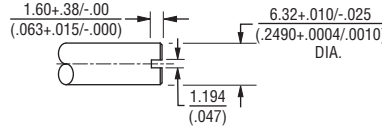

STD. LENGTHS:

12.70 (.500)	15.88 (.625)	19.05 (.750)	22.23 (.875)
-----------------	-----------------	-----------------	-----------------

**SHAFT TYPE "H" (USES BUSHING A)**

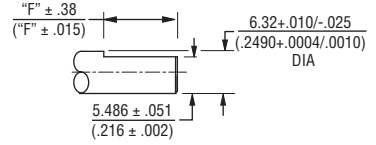

STD. LENGTHS:

19.05 (.750)	22.23 (.875)
-----------------	-----------------

FLAT LENGTH "F":

7.95 (.313)	11.13 (.438)
----------------	-----------------

**SHAFT TYPE "J" (USES BUSHING R)**

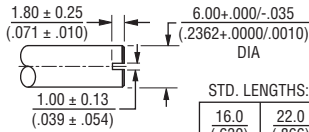

STD. LENGTHS:

16.0 (.630)	22.0 (.866)
----------------	----------------

TOLERANCES EXCEPT AS SHOWN: .XX = ± .02  
 (.050)  
 .XXX = ± .005  
 (.127)  
 .XXXX = ± .0005  
 (.0127)

DIMENSIONS:  $\frac{\text{MM}}{\text{(INCHES)}}$

**How to Order**

**91 A 2 A - G 28 - L 15 / L15 L**

Part number for multiple section potentiometers must have a taper and resistance value for each section.

ANTI-ROTATION LUG	
A	Single .305" (7.8 mm) R, 90° CW
D	No Lug

# SECTIONS	
1	Single
2	Dual

BUSHING	
A	Metal Plain 3/8" (9.53 mm) D x 3/8" (9.53 mm) L
C	Metal Plain 1/4" (6.35 mm) D x 1/4" (6.35 mm) L
R	Metal Plain 10 mm D x 9 mm L

SHAFT LENGTH (FMS)		AVAILABLE ONLY IN BUSHING	
Code	Description	Code	
16	1/2" L	A, C	
20	5/8" L	A, C	
24	3/4" L	A, C	
28	7/8" L	A	
32	1" L	A	
METRIC			
16	16 mm L	R	
22	22 mm L	R	

RoHS IDENTIFIER	
L	Compliant

ELEMENT TAPER TYPE/TOLERANCE		RESISTANCE CODE VALUE IN OHMS
L	Long Life Linear C-P ±10 %	(10) - 1 K (13) - 5 K (15) - 10 K

MODEL	
91	Single-Turn, In-Line PC Pins
92	Single-Turn, In-Line J-Hooks
93	Single-Turn, L-Pattern PC Pins
95	Single-Turn, Triangle-Pattern Solder Lugs

SHAFT TYPE	AVAILABLE ONLY IN	
	LENGTHS (CODE)	BUSHINGS (CODE)
E Metal Single Slotted 1/8" (3.18 mm) D	16, 20, 24	C
G Metal Single Slotted 1/4" (6.35 mm) D	16, 20, 24, 28	A
H Metal Single Flatted 1/4" (6.35 mm) D	24, 28	A
J Metal Single Slotted 6 mm D	Metric 16, 22	R

*Boldface features are Bourns standard options. All others are available with higher minimum order quantities.*

08/27/13

Specifications are subject to change without notice. The device characteristics and parameters in this data sheet can and do vary in different applications and actual device performance may vary over time. Users should verify actual device performance in their specific applications.

For more information about this product, visit our website at:

[www.potentiometers.com](http://www.potentiometers.com)